

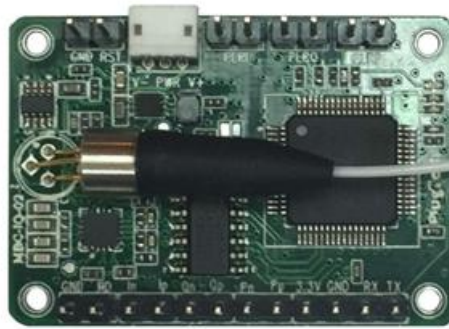

Ultra High Precision MZM Bias Controller



Introduction

Rofea' modulator bias controller is specially designed for Mach- Zehnder modulators to ensure a stable operation state in various operating environments. Based on its fully digitized signal processing method, the controller can provide ultra stable performance.

The controller injects a low frequency, low amplitude dither signal together with bias voltage into the modulator. It keeps reading the output from the modulator and determines the condition of the bias voltage and the related error. A new bias voltage will be applied afterwards according to the previous measurement. In this way, the modulator is ensured to work under proper bias voltage.

Feature

- Bias voltage control on Peak/Null/Q+/Q-
- Bias voltage control on arbitrary point
- Ultra precise control:
 - 50dB maximum extinction ratio on Null mode
 - $\pm 0.5^\circ$ accuracy on Q+ and Q- modes
- Low dither amplitude:
 - 0.1% V_π at NULL mode and PEAK mode
 - 2% V_π at Q+ mode and Q- mode
- High stability: with fully digital implementation
- Low profile: 40mm(W) \times 30mm(D) \times 10mm(H)
- Easy to use:
 - Manual operation with mini jumper
 - Flexible OEM operations through MCU UART2
- Two different modes to provide bias voltage:
 - a. Automatic bias control
 - b. User defined bias voltage



Application

- LiNbO₃ and other MZ modulators
- Digital NRZ, RZ
- Pulse applications
- Brillouin scattering system and other optical sensors
- CATV Transmitter

Ordering Information

Part No.:R-BC-ANY
Contact: bjrofoc@rof-oc.com

¹The highest extinction ratio depends on and cannot exceed modulator maximum extinction ratio.

²UART operation is only available on some version of the controller.



Performance



Figure 1. Carrier Suppression

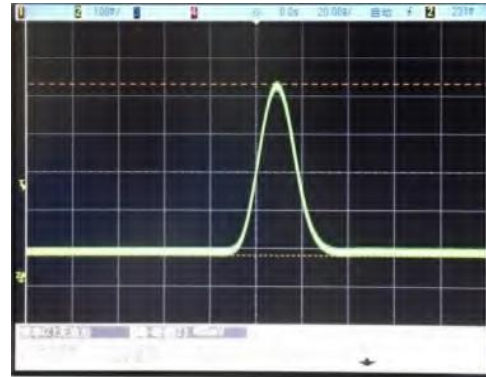

Figure 2. Pulse Generation



Maximum Power
at Peak Point

Figure 3. Modulator max power



Minimum Power
at Null Point

Figure 4. Modulator minimum power

Maxim DC extinction ratio

In this experiment, no RF signals were applied to the system. Pure DC extinction has been measured.

1. Figure 5 demonstrates the optical power of modulator output, when modulator controlled at Peak point. It shows 3.71dBm in the diagram.
2. Figure 6 shows the optical power of modulator output, when modulator controlled at Null point. It shows -46.73dBm in the diagram. In real experiment, the value varies around -47dBm; and -46.73 is a stable value.
3. Therefore, the stable DC extinction ratio measured is 50.4dB.

Requirements for high extinction ratio

1. System modulator must have high extinction ratio. Characteristic of system modulator decides the maximum extinction ratio can be achieved.
2. Polarization of modulator input light shall be taken care of. Modulators are sensitive to polarization. Proper polarization can improve extinction ratio over 10dB. In lab experiments, usually a polarization controller is needed.
3. Proper bias controllers. In our DC extinction ratio experiment, 50.4dB extinction ratio has been achieved. While the datasheet of the modulator manufacture only lists 40dB. The reason of this improvement is that some modulators drift very fast. Rofea R-BC-ANY bias controllers update the bias voltage every 1 second to ensure fast track response.



Specifications

Parameter	Min	Typ	Max	Unit	Conditions
Control Performance					
Extinction ratio		MER ¹	50	dB	
CSO ²	-55	-65	-70	dBc	Dither amplitude: 2%V _π
Stablization time		4		s	Tracking points: Null & Peak
		10			Tracking points: Q+ & Q-
Electrical					
Positive power voltage	+14.5	+15	+15.5	V	
Positive power current	20		30	mA	
Negative power voltage	-15.5	-15	-14.5	V	
Negative power current	2		4	mA	
Output voltage range	-9.57		+9.85	V	
Output voltage precision		346		μV	
Dither frequency	999.95	1000	1000.05	Hz	Version: 1kHz dither signal
Dither amplitude		0.1%V _π		V	Tracking points: Null & Peak
		2%V _π			Tracking points: Q+ & Q-
Optical					
Input optical power ³	-30		-5	dBm	
Input wavelength	780		2000	nm	

¹ MER refers to Modulator Extinction Ratio. The extinction ratio achieved is typically the extinction ratio of modulator specified in modulator datasheet.

² CSO refers to composite second order. To measure CSO correctly, the linear quality of RF signal, modulators and receivers shall be ensured. In addition, the system CSO readings may vary when running at different RF frequencies.

³ Please be noted that input optical power does not correspond to the optical power at selected bias point. It refers to the maximum optical power that the modulator can export to controller when bias voltage ranges from -V_π to +V_π.

User Interface

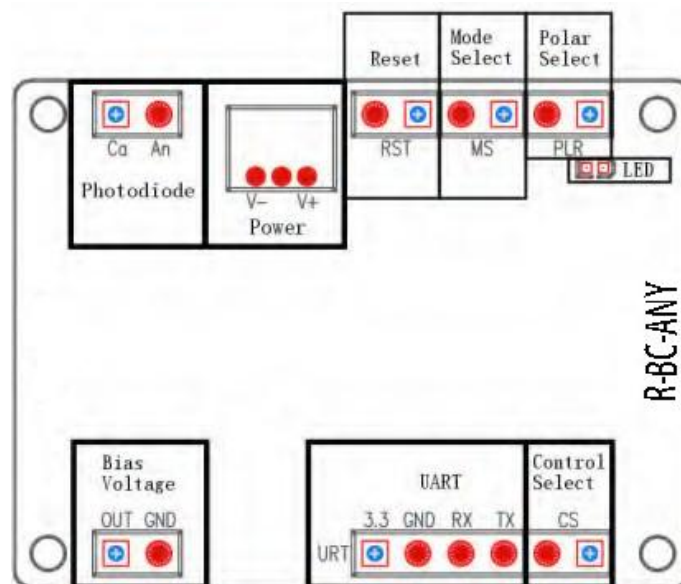

Figure5. Assembly



Group	Operation	Explanation
Photodiode ¹	PD: Connect MZM photodiode's Cathode	Provide photocurrent feedback
	GND: Connect MZM photodiode's Anode	
Power	Power source for bias controller	V-: connects the negative electrode
		V+: connects the positive electrode
		Middle probe: connects the ground electrode
Reset	Insert jumper and pull out after 1 second	Reset the controller
Mode Select	Insert or pull out the jumper	no jumper: Null mode; with jumper: Quad mode
Polar Select ²	Insert or pull out the jumper	no jumper: Positive Polar; with jumper: Negative Polar
Bias Voltage	Connect with the MZM bias voltage port	OUT and GND provide bias voltages for modulator
LED	Constantly on	Working under stable state
	On-off or off-on every 0.2s	Processing data and searching for controlling point
	On-off or off-on every 1s	Input optical power is too weak
	On-off or off-on every 3s	Input optical power is too strong
UART	Operate controller via UART	3.3: 3.3V reference voltage
		GND: Ground
		RX: Receive of controller
		TX: Transmit of controller
Control Select	Insert or pull out the jumper	no jumper: jumper control;with jumper:UART control

¹ Some MZ modulators have internal photodiodes. Controller setup should be chosen between using controller's photodiode or using modulator's internal photodiode. It is recommended to use controller's photodiode for Lab experiments for two reasons. Firstly, controller photodiode has ensured quality. Secondly, it is easier to adjust the input light intensity. Note: If using modulator's internal photodiode, please make sure that the output current of photodiode is strictly proportional to input power.

² Polar pin is used to switch the control point between Peak and Null in Null control mode(determined by Mode Select pin) or Quad+ and Quad- in Quad control mode. If jumper of polar pin is not inserted, the control point will be Null in Null mode or Quad+ in Quad mode. Amplitude of RF system will also affect the control point. When there is no RF signal or RF signal amplitude is small, controller is able to lock the work point to correct point as selected by MS and PLR jumper. When the RF signal amplitude exceeds certain threshold, polar of the system will be changed, in this case, the PLR header should be in the opposite state, i.e. the jumper should be inserted if it is not or pulled out if it is inserted.

Typical Application

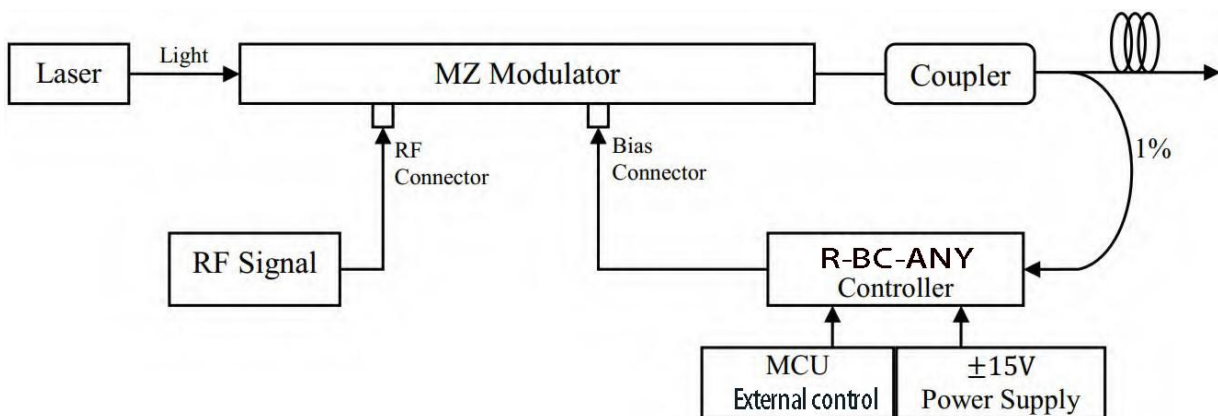

The controller is easy to use.

Step1. Connect 1% port of the coupler to the photodiode of the controller.

Step2. Connect bias voltage output of the controller(through SMA or 2.54mm 2-pin header) to bias port of the modulator.

Step3. Provide controller with +15V and -15V DC voltages.

Step4. Reset the controller and it will start to work.

NOTE. Please be ensured that RF signal of the whole system is on before resetting the controller.